



SMB360, SMB500, SMB700

Features

- Stainless steel body
- Freestanding, high spin
- Oversized frame, bearings and drum
- Large drain valve (2 x Ø 76 mm)
- Easy access to all parts
- Frequency controlled motor
- Large door opening for easy loading and unloading.
- Control QED Select – new graphic display enables:
 - Communication interface enabling remote service
 - Multilingual microprocessor
 - Fully programmable
- RS485 & USB plug
- Perforated lifting ribs: better washing results, lower water consumption
- Eco-friendly washing programs – significantly reduces water and electricity consumption
- Patented soap dispenser with 5 removable compartments

Options

- Liquid soap pumps
- Automatic weighing system by weighing cells for measuring exact capacity of the linen
- Second display (located on clean side)
- Light and horn signalisation the end of wash cycle
- Tap to take water samples
- Air operated water inlets
- Isolation for energy and noise reduction
- Drain valve for water recycling
- Lateral drain
- Version without soap hopper

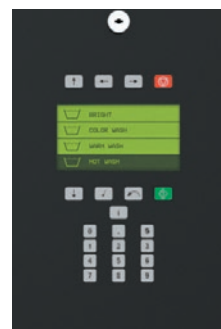

Control panel QED Select



Easy Operation



Robust Design



Large Door Opening



Hygienic Solution

On-Premises Barrier Washer-Extractors

Specifications

	SMB360	SMB500	SMB700
CAPACITY			
Drum capacity [kg/lb]	36/79	50/110	70/154
Drum volume [l]	360	500	700
Drum diameter [Ø mm]	775		
Drum depth [mm]	764	1060	1484
Number of drums	1	1	2
Number of loading doors	1	1	2
Number of unloading doors	1	1	2
motor			
Power [kW]	4	7.5	7.5
DRUM SPEED			
Washing speed (default) [rpm]	41	41	41
Highest spin speed (default) [rpm]	900	900	900
G-Factor spin speed	350	350	350
PROGRAMMER			
Type of control	QED Select	QED Select	QED Select
Cabinet			
Door opening angle [°]	155	155	155
HEATING			
100% hot water [°C]	90	90	90
100% electrical [kW]	36	48	60
Steam high pressure [bar]	3 – 8	3 – 8	3 – 8
CONNECTIONS			
Electrical [V/Hz]	3×200–240V/50–60Hz 3×380–415V/50–60Hz 3×440–480V/50–60Hz	3×200–240V/50–60Hz 3×380–415V/50–60Hz 3×440–480V/50–60Hz	3×200–240V/50–60Hz 3×380–415V/50–60Hz 3×440–480V/50–60Hz
Water inlet [in]	3 × 1"	3 × 1"	3 × 1"
Steam inlet [in]	¾"	¾"	¾"
Drain diameter [in]	2 × 3"	2 × 3"	2 × 3"
DIMENSIONS			
Size HxWxD [mm]	1700×1270×980	1700×1566×980	1700×2032×980
TRANSPORT DATA			
Gross weight [kg]	960	1130	1310
Net weight[kg]	1090	1280	1470
Packing dimensions HxWxD [mm]	2005×1530×1255	2005×1830×1195	2005×2290×1195

The data concerning dimensions of machines include all extended parts

On-Premises Barrier Washer-Extractors

Dimensions

Front view SMB360, SMB500

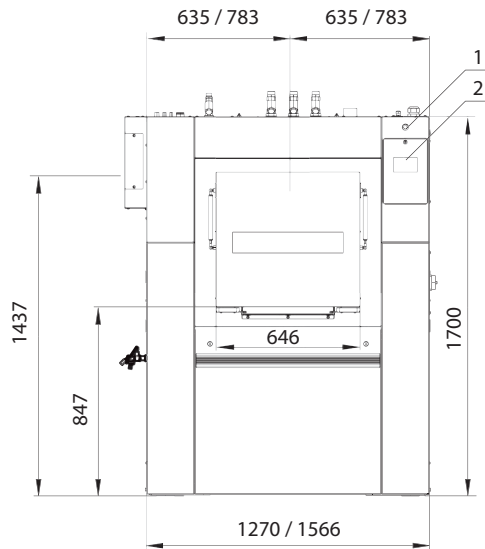

Front view SMB700

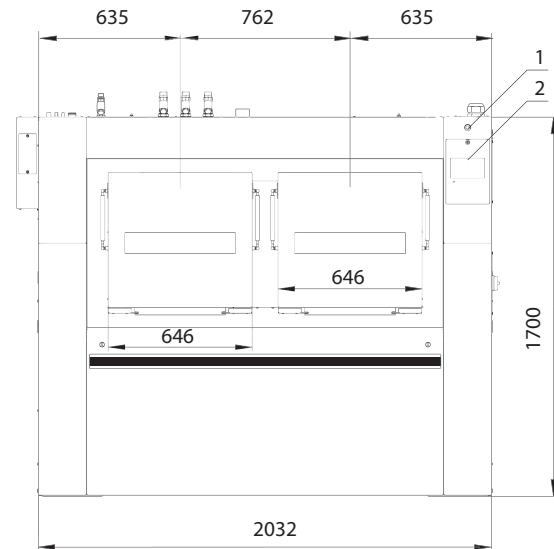

Side view SMB360, SMB500, SMB700

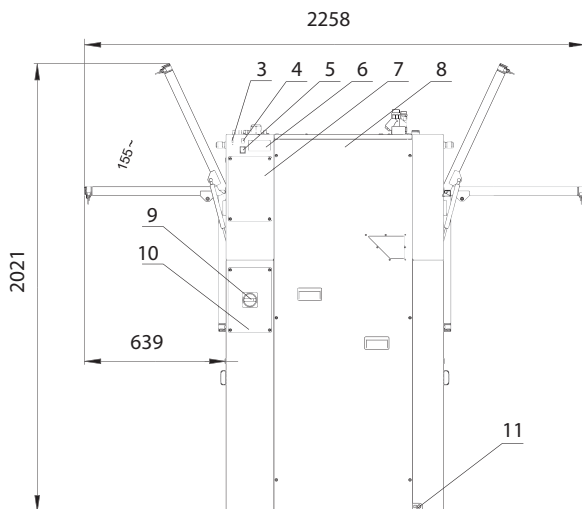

- 1 Emergency Stop
- 2 Control Panel
- 3 USB Port
- 4 PC Programming Connection
- 5 Switch: Steam / Electric Heating
- 6 Serial Plate
- 7 Electrical Signals Liquid Soap Cover
- 8 Electrical Components with Frequency Inverter Cover
- 9 Main Switch Cover
- 10 Main Switch
- 11 Equipotential Bounding Terminal